

IFN10

Ex d IIC T5
Zone 1 & Zone 2



Features

- Fire & Ignition proof.
- Fan blade dynamically balanced for noise free operation.
- Constant air delivery for life long.
- Epoxy powder coated as per IS : 5
- Energy saving efficiency and low heat produce.
- Cast iron housing for excellent heat management.
- Quick installation, special design,
- Highly reliable professional design.

Applications

- Chemical Industry, Paint Industry,
- Fertilizer Industry, Oil & Gas Industry,
- LPG Bottling Industry, Pharma Industry,
- Steel Industry, Cement Industry, Mines
- Refineries & Petrochemicals.

Characteristics

Applicable Use

- Zone 1 & Zone 2
- Gas group IIA, IIB, IIC
- Temperature Class T5

Earthing Terminal

- 1 Internal
- 2 External

Motor Body

- Cast iron - powder coated
- Excellent thermal conductivity

Cable Entry

- 3/4" ET - 2 Nos.

Standards Compliance

- IS/IEC 60079-0 : 2017
- IS/IEC 60079-1 : 2014
- Cat. No.: ILS/AIR...

Mounting

- Structure / Wall

Installation

- Easy installation

Blade material

- Aluminium Powder coated



0.25HP / 0.33HP / 0.50HP / 1.0HP



240V AC/415V AC, 50/60Hz



1440 RPM / 960 RPM



12" / 16" / 18" / 24"



Ta: 0°C to 45°C

Housing Color



Powder Coated – DA Grey (RAL 7005)

*All Dimensions are in mm

Product Code

Product Code	Bland Size (Inch)	Horse Power (HP)	RPM	Phase	Body Color	CFM (Approx.)	Weight (Kg)
IFN10-12EX1440G1PXX	12"	0.25	1440	1	Grey	1260	10.5
IFN10-12EX1440G3PXX	12"	0.25	1440	3	Grey	1260	10.5
IFN10-16EX1440G1PXX	16"	0.33	1440	1	Grey	2510	12
IFN10-16EX1440G3PXX	16"	0.33	1440	3	Grey	2510	12
IFN10-18EX1440G1PXX	18"	0.50	1440	1	Grey	4210	17
IFN10-18EX1440G3PXX	18"	0.50	1440	3	Grey	4210	17
IFN10-24EX0960G1PXX	24"	1.00	960	1	Grey	6110	21.5
IFN10-24EX0960G3PXX	24"	1.00	960	3	Grey	6110	21.5

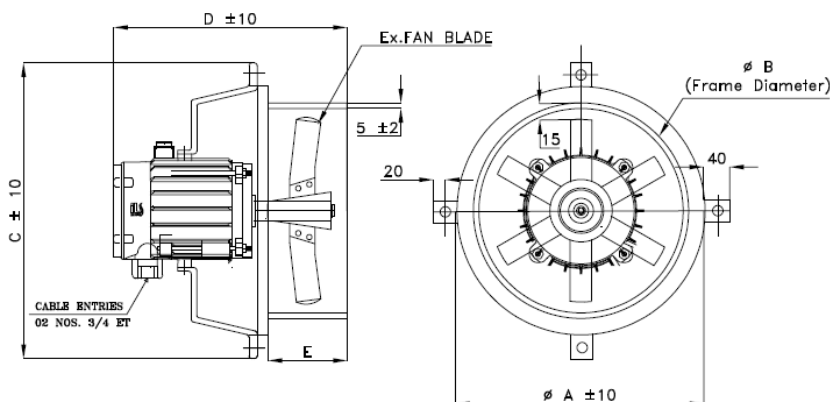

Sr.No.	CAT NO.	Blade Size	φ A	φ B	C	D	E
1	ILS/AIR/EX12/01	12"(300)	360	336	440	365	75
2	ILS/AIR/EX16/01	16"(406)	466	442	508	375	85
3	ILS/AIR/EX18/01	18"(457)	517	493	559	385	95
4	ILS/AIR/EX24/01	24"(600)	660	636	702	410	130

Custom Order



Accessories

Optional at Extra Cost

- Double Compression Cable Gland Brass/SS – 3/4" ET
- Stopper Plug Brass/SS/MS – 3/4" ET
- Front & back wire mesh
- Louver
- Bird catcher